



SmartDial Speech PX

User Guide

**Issue A
03/05/00**

Introduction	4
EC Declaration of Conformity	5
Suitability for Use.....	5
Features	6
Exchange Voltage Monitoring.....	6
Line Blocked Detection.....	6
Series Telephone Handset Connection.....	6
DTMF Dialling	7
Reporting	7
Multiple Message Reporting.....	7
Primary/Backup Reporting	7
Programmable Open/Close Code Reporting	7
Restore Code Reporting	8
Paging Reports	8
Alarm Reporting	8
Fast Format Alarm Reporting.....	8
Ademco Superfast Format.....	9
Guardall PS002 Alarm Reporting	9
High Speed 'Point - ID' Alarm Reporting.....	9
Speech Alarm Reports	9
Installation Instructions.....	10
Package Contents	10
Note to Supplier.....	10
Installation.....	10
Programming Instructions	12
Configuration Programming	12

Remote Telephone Logon	13
Local Telephone Logon	13
Message Recording & Playback	13
Control Panel Outputs Control	14
Statutory Warning	15
Statutory Requirements.....	15
Ringer Equivalence Number (REN)	15
Dialling Modes.....	15
Locally Initiated Test Calls	15
Default Configuration.....	15
Remote Up/Download	16
LED Status Indicators	16
Compatibility with BT ‘Redcare’ Lines	16
Timed Break Register Recall (“Star Services” in UK).....	16
Available Facilities	16
Repeat Attempts.....	17
Application Form for Installation of Modular Telephone Sockets	18

Introduction

The SmartDial Speech PX is a fully featured auto-dialling, auto answering Digital Alarm Communicator designed as an optional attachment to the Guardall PX range of Alarm Control Panels. The list of Standard Features includes:

- Local and remote telephone recording/playback of 4 speech messages.
- DTMF receive capability for local/remote control of the Panel
- Local SmartDial Speech PX Programming
- Exchange Voltage Monitoring
- Line Blocked Detection
- Compatibility with BT 'Redcare' lines
- Series Handset Disconnect
- DTMF Dialling
- Default Configuration
- 8 Channel Fast Format Alarm Reporting
- Guardall PS002 Modem Format Alarm Reporting
- Ademco Superfast Format
- Programmable Open/Close Code Reporting
- High Speed 'Point - ID' Alarm Reporting
- Programmable Restore Code Reporting
- Multiple Message Reporting
- Primary/Secondary Reporting
- Paging Reports
- Timed Break Recall ("Star Services" in the UK)
- Locally initiated Test call
- Remote Up/Download of Panel Settings and Event Logs
- 5 LED Status Indicators

EC Declaration of Conformity

We: Guardall Limited

Lochend Industrial Estate
NEWBRIDGE
EH28 8PL
UK

declare under sole responsibility that the following product:

Equipment Name: SmartDial Speech PX
Model Number: W73825

is in conformity with the following relevant standards:

BS EN50081-1:1992	Generic Emission Standard For Residential, Commercial & Light Industry.
BS EN50082-1:1992	Generic Immunity Standard For Residential, Commercial & Light Industry.
EN60950:1992	Safety of Information Technology Equipment, Including Electrical Business Equipment.
TBR21	Attachment Requirements for Connection to the Analogue Public Switched Networks

following the provisions of Council Directive 1999/5/EC on radio and telecommunications terminal equipment and the mutual recognition of their conformity.

Test Report: EMC00047

PCN:

Signed:

Date:

Name: Andrew W Smith

Position: Managing Director

On behalf of: Guardall Limited

Suitability for Use

SmartDial Speech PX must not be modified in any way. The output power is fixed and can not be changed by the user.

SmartDial Speech PX is intended for installation inside Guardall's PX range of Alarm Control Panels.

SmartDial Speech PX is intended for normal office, household and similar indoor use. It should not be used in damp or humid environments such as bathrooms or swimming pools.

Features

Exchange Voltage Monitoring

As a protection against a cut line or telephone line fault, the nominal supply voltage from the telephone exchange is continuously monitored. If a fault condition occurs for more than approximately 5 seconds, the Control Panel is informed of the 'loss of line' condition. When the line is restored, the Control Panel is informed after approximately 5 seconds.

The Control Panel may be programmed to respond to line faults with a delay of up to 255 seconds, or programmed not to recognise line faults at all.

If SmartDial Speech PX has an attached telephone handset, then a 'loss of line' condition will exist whenever the handset is in use. In this case the Control Panel must be programmed with the 'handset' programming option selected. Refer to the Control Panel manual for details.

Line Blocked Detection

In some circumstances, for example when the telephone exchange has removed outgoing service, or when an incoming caller has not released the line and effectively blocked outgoing calls, the exchange voltage may be present but no proceed indication (dial tone) exists, or an out of service tone is present.

In this case, SmartDial Speech PX can be programmed to periodically test for a 'blocked' line (every hour) and report any problem to the Control Panel. After clearing of a line-blocked condition, SmartDial Speech PX will report this back to the Control Panel after approximately 10 seconds. Checking is done by looking for the dial tone, dialling the first digit of one of its' telephone numbers and ensuring that the dial tone disappears.

If the handset option is programmed, 'line blocked' will only be reported when the Control Panel is FULLY SET.

Series Telephone Handset Connection

Provision has been made to allow for connection of up to three telephone handsets on the same telephone line as SmartDial Speech PX. These handsets **MUST** be connected in series with SmartDial Speech PX, with SmartDial Speech PX the first apparatus connected to the master telephone socket. Connection of SmartDial Speech PX and telephone handsets are made via connector CN1 on the network side of the circuit board.

When any handset is attached, the communicator must be programmed so that it is made aware of such an attachment. This avoids having the 'loss of line' conditions reported when the handset is in use, causing line fault transmissions to the Central Station.

If a handset and line blocked are both programmed, then Line Blocked and Exchange Voltage reporting back to the Control Panel will be suppressed unless the Control Panel is fully set.

Connecting handsets and SmartDial Speech PX in any configuration other than the method stated above (such as parallel connection) will invalidate network connection approval.

DTMF Dialling

The communicator uses DTMF tones to dial programmed telephone numbers. Normally, dialling will only commence in the presence of a valid proceed indication (dial tone) and will employ 'Timed Break Recall' after 5 seconds in the absence of the dial tone. If the exchange still fails to provide a dial tone, SmartDial Speech PX will release the line after a further 5 seconds. This will use up one connect attempt.

In some circumstances, such as dialling through a PABX or where exchange tones are not reliable, SmartDial Speech PX may be programmed to perform dialling (blind dialling) without first checking for dial tone.

Reporting

Multiple Message Reporting

The possibility of missing rapidly changing events is greatly reduced by the inclusion of an event history buffer in SmartDial Speech PX. Any alarm event sent to SmartDial Speech PX will be stored in a queue for sending to the Central Station receiver, with messages sent to the Central Station taken off the queue in a first come, first processed basis. As messages are transmitted, more events can be received, processed and transmitted within the current telephone call. Multiple Message Reporting does not apply to Speech Alarm Reports.

Primary/Backup Reporting

SmartDial Speech PX will attempt to call the receiver at the Primary Telephone number that has been programmed into the Control Panel. If all attempts fail at the Primary number, and if a telephone number has been entered in the Backup Number Store, SmartDial Speech PX will then attempt to call the receiver at the Backup Telephone number(s). If all attempts fail, then the communications failure status is sent to the Control Panel.

As soon as a receiver is contacted, and all the outstanding alarms transmitted, the sequence is halted. If a message was successfully transmitted, then Comms OK is reported to the Control Panel and the Control Panel event log will record 'Comm OK n'. If the message was unsuccessful, then the Control Panel event log will read 'Comm Fail n', where n is the appropriate number store. Receivers can be compatible with Ademco Fast or Superfast Format, 'Point-ID', PS002, or hand pager format.

Channel messages 1,2 and 3 are associated with the Control Panel Communicator Outputs OP1, OP2 and OP3, respectively. For an alarm message to be initiated, the Control Panel's Communicator Output(s) must be mapped to a Control Panel Output Function. Refer to the Control Panel manual for more details.

Programmable Open/Close Code Reporting

All 8 channels do not necessarily represent alarm data. Any of the 8 channels may be programmed to report a modified code. The alarm receiver will interpret 'open' instead of 'alarm' and 'close' instead of 'restore' for these channels.

Selection of Open/Close will override selection of Alarm/Restore Reporting. Close codes are always reported in this instance.

The 8 channels can be programmed in any combination of Alarm Only, Alarm/Restore and Open/Close code reporting.

Restore Code Reporting

When any channel goes into alarm the communicator will always initiate an alarm report call.

Normally the communicator ignores any alarm to restore transition. However, any channel(s) programmed for restore reporting will report the restore condition.

Paging Reports

SmartDial Speech PX can be programmed to report alarm events to a remote hand held radio pager. In the UK, Mercury and Vodapage paging formats are supported with information transmissions in either Direct Numeric or Stored Message Mode.

- Direct Numeric: Message received is as follows:

(4 digit site ID) (1 digit Ademco Event) (1 digit Channel in Alarm)

- Stored Message: This allows a more descriptive message to be received, but cannot display the site ID. The channel in alarm is transmitted to the pager where one of the six pre-programmed text descriptions is displayed, e.g., FIRE, BURGLARY, etc.,

Alarm Reporting

Fast Format Alarm Reporting

Alarm data is represented by the state of 8 channels. When any channel changes state, the communicator is triggered to initiate a call to the programmed central station receiver. Each channel can assume one of six states: No Alarm, New Alarm, Continuing Alarm, Alarm Restore, New Opening or New Closing.

The manner in which the transitions between these states are reported to the Central Station is dependent upon how the communicator is programmed to respond. For example, the Channel information may be encoded in the following way...

Channel	Designated Meaning
1	Fire
2	PA
3	Intruder
4	Full Set
5	Isolated Set
6	Tamper
7	Mains Fail
8	Verify

....or any other combination which the Control Panel has been programmed to report. The actual meaning given to each channel is known only to the Control Panel and the Central Station - it does not need to be known by SmartDial Speech PX.

Alarm and restore events are reported to the programmed Central Station using the protocol defined in the draft IEC publication 839 part 8 - "DTMF protocol for use in Digital Communicator Systems at Interfaces with the PSTN". The protocol types supported are as follows:

a)	4-8-1/1	4 digit UID, 8 digit channel data, 1 digit status	handshake type 1
b)	4-8-1/2	4 digit UID, 8 digit channel data, 1 digit status	handshake type 2

Ademco Superfast Format

This is an enhancement to the standard fast format reporting and is user selectable as a programmed option. The standard Fast Format protocol at the Central Station receiver requires to see two identical messages before it accepts the message as valid (a basic method of error detection). The Superfast Format sends the message only once, and relies on the appending of a suitable checksum digit onto the message for its error detection. This offers both time and communication cost savings.

Guardall PS002 Alarm Reporting

It is possible to send Guardall PS002 type alarm reports to a remote PC, MAS or GuardStation system. This is a modem format, which offers many advantages over standard alarm messages.

Alarm data is sent containing the date, time, event identifier and event status.

High Speed 'Point - ID' Alarm Reporting

This is an alarm reporting protocol, which allows additional data to be transmitted to the Central Station without resorting to a modem format. It uses DTMF transmission with a message content significantly different from standard Fast Format protocols.

With normal alarm reporting, a single alarm code is transmitted to the Central Station when one or several zones have been triggered. This method does not pinpoint the active zone(s). With 'Point - ID' each zone can be uniquely identified thus aiding in the investigation of alarm sources.

A list of supported 'Point - ID' codes are provided in the communications section of the Control Panel manual.

Speech Alarm Reports

Four seconds after dialling, the speech message will be transmitted followed by the end of message tone. If speech acknowledgement is programmed ON, SmartDial Speech PX then waits up to 4.5 seconds for the acknowledge tone (any DTMF digit). If no acknowledge is received then the message is repeated. This process will continue for a maximum of 5 attempts (120 seconds limit), or until the message is acknowledged.

If the speech message is not acknowledged (e.g., if the call has been redirected to a mobile phone's voice-mail), SmartDial Speech PX will generate a communications fail message. The normal programmed call sequence will then take over.

Note that the Control Panel's Alarm Format must be set to 'Speech' for speech alarm reports to be initiated.

Installation Instructions

IMPORTANT - THESE INSTRUCTIONS MUST BE READ IN FULL BEFORE ATTEMPTING TO INSTALL OR USE THE COMMUNICATOR ON THE TELEPHONE NETWORK.

Package Contents

1. SmartDial Speech PX
2. User Guide
3. Form to Request Installation of BT type socket.

If any of these items are missing or damaged please contact your supplier.

Note to Supplier

The approval status is invalidated if the User Instructions are not provided with the communicator.

The SmartDial Speech PX Communicator has been approved as an auto dialling, auto answer modem which may only be used with compatible intelligent alarm control panels.

SmartDial Speech PX can share the use of a telephone line with up to three conventional telephone handsets.

IN THIS CASE THE TELEPHONE HANDSETS MUST BE CONNECTED SUCH THAT THE COMMUNICATOR WILL OVERRIDE HANDSET OPERATION IN THE EVENT OF AN ALARM CALL BEING ATTEMPTED. (See connection diagram)

The SmartDial Speech PX Communicator has two ports:

1. Telecommunications network voltage port 'CN1', with screw terminals 'A' and 'B' for the telephone line connections, and 'TA' and 'TB' for attached handset(s) connections.
2. Safety extra low voltage port 'CN2', for connections to the host Control Panel bus, low voltage power lines, and local recording telephone handset.

Installation

DANGEROUS VOLTAGES MAY BE PRESENT ON THE TELECOMMUNICATIONS NETWORK, THEREFORE THE ALARM CONTROL PANEL MUST NOT BE OPENED WHILST CONNECTED TO THE MASTER TELEPHONE SOCKET.

It is essential that SmartDial Speech PX is installed such that with the exception of the connections to SmartDial Speech PX, a clearance distance of 4.0mm and a creepage distance of 6.5mm is maintained between SmartDial Speech PX and other assemblies within the Alarm Control Panel.

1. Obtain a suitable telephone line.
2. Install the SmartDial Speech PX in the Control Panel according to the Control Panel's installation instructions.
3. Connect the telephone line cord to Connector CN1.
4. Connect any other telephone handsets to Connector CN1.
5. Connect the Control Panel interface (and, if required, local handset) to Connector CN2.
6. Use plastic cable ties to secure cables and provided strain relief.
7. Refit the Control Panel cover and secure all case screws.
8. Connect the telephone line cord to the master socket.
9. Apply power and test the system.

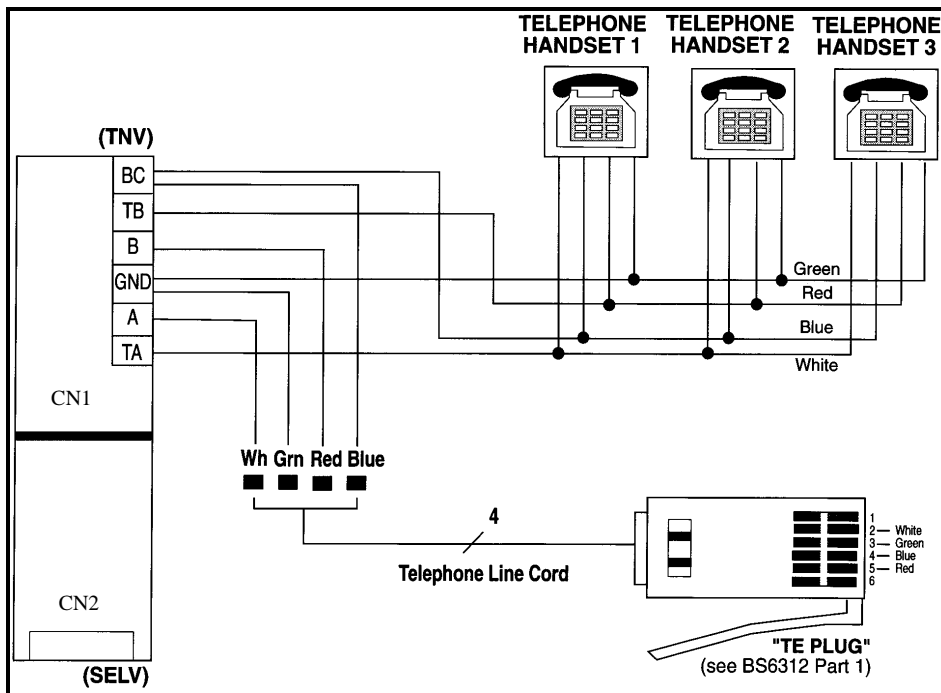

Diagram 1: Telephone Line and Handset Connections

CN1	Telephone Line & Handsets	1 BC
		2 TB
		3 B
		4 Ground
		5 A
		6 TA
CN2	Panel & Local Handset Interface	1 +
		2 -
		3 A
		4 B
		5 A Handset
		6 B Handset

The host Control Panel safety extra low voltage (SELV) port should only be connected to port CN2 of SmartDial Speech PX.

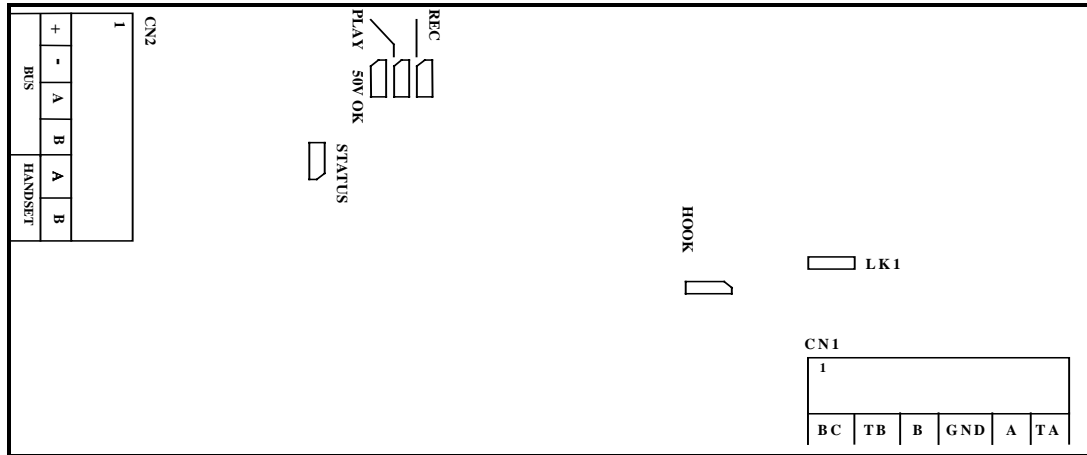

Diagram 2: Circuit Board Identification

The SmartDial Speech PX Communicator requires a 12V dc power supply at 350mA rating, which is supplied by the host Alarm Control Panel.

The power supply in the Alarm Control Panel must not become overloaded by the combined power requirements of all the installed card options.

In order to maintain the independent approval of the SmartDial Speech PX communicator, it is essential that the other optional cards do not use or generate mains supply voltages or any other hazardous voltage. A hazardous voltage is a voltage exceeding 42.4V peak ac or 60V dc. Consult a telecommunication engineer before proceeding if you have any doubt.

For a host using or generating voltages greater than 300V (rms or dc), consult a telecommunications engineer before installation of the alarm system.

The above problems will not be encountered if the Alarm Control Panel's instructions are adhered to.

You are reminded that the SmartDial Speech PX Communicator should only be used when mounted inside the host Alarm Control Panel in such a way as to be inaccessible without the use of tools.

This means that you must refit the SmartDial Speech PX in the host using the fixings provided and secure all case screws.

Programming Instructions

Configuration Programming

SmartDial Speech PX Configuration items can be locally programmed via an Alarm Control Panel LCD keypad.

Remote Telephone Logon

The Control Panel's Remote Message Option must be on for remote recording and playback.

1. Dial the SmartDial Speech PX telephone number. The communicator will answer on its pre-programmed number of rings with a single long tone.
2. Enter any valid user PIN code then press the # key. A double tone indicates that DTMF control mode was successfully entered.

Local Telephone Logon

1. Connect the local telephone handset as described in the Installation section of the User Guide.
2. Enter any valid user PIN code then press the # key. A double tone indicates that DTMF control mode was successfully entered.

Message Recording & Playback

The user can record one main message of 11 seconds duration, and three channel messages, each of 3 seconds duration.

1. Log on from a local or remote telephone.
2. To start recording a message, enter the desired record function code (the table below lists the available function codes). A single tone will be heard once the # key has been pressed, indicating that recording has started. On completion of the pre-set recording time a single tone will be heard. Repeat this step to record another message.
3. To playback a message, enter the desired playback function code. The message will be played back after the # key has been pressed. No tone indication is given for start and stop of playback. Repeat this step to playback another message.
4. Enter * then # to exit DTMF control mode and make the communicator hang up. A double tone indicates that the command has been accepted.

The communicator will indicate invalid codes with 4 tones in quick succession.

*	Cancel command
*#	Exit DTMF control mode (communicator will go on-hook)
40#	Start recording of the main message
41#	Start recording of channel 1 alarm message
42#	Start recording of channel 2 alarm message
43#	Start recording of channel 3 alarm message
50#	Start playback of the main message
51#	Start playback of channel 1 alarm message
52#	Start playback of channel 2 alarm message
53#	Start playback of channel 3 alarm message

Control Panel Outputs Control

The user may control up to eight, independent Control Panel outputs from a remote or local DTMF telephone.

1. Log on from a local or remote telephone.
2. To switch an output on/off, enter the desired function code (the table below lists the available function codes). A double tone will be heard once the # key has been pressed, indicating the command was acknowledged. Repeat this step to switch another output.
3. Enter * then # to exit DTMF control mode and make the communicator hang up. A double tone indicates that the command has been accepted.

The communicator will indicate invalid codes with 4 tones in quick succession.

Code	Function
*	Cancel command
*#	Exit DTMF control mode (communicator will go on-hook)
61#	Turn on output(s) 1
62#	Turn on output(s) 2
63#	Turn on output(s) 3
64#	Turn on output(s) 4
65#	Turn on output(s) 5
66#	Turn on output(s) 6
67#	Turn on output(s) 7
68#	Turn on output(s) 8
71#	Turn off output(s) 1
72#	Turn off output(s) 2
73#	Turn off output(s) 3
74#	Turn off output(s) 4
75#	Turn off output(s) 5
76#	Turn off output(s) 6
77#	Turn off output(s) 7
78#	Turn off output(s) 8

Statutory Warning

This apparatus is designed for operation with a low voltage supply of 12V dc at 350 mA rating. There is no user protection in the SmartDial Speech PX digital communicator against supplies having voltages in excess of this. Users of this apparatus should ensure that any power supply provided for use with this apparatus complies with the relevant legal safety standards when properly assembled, installed and maintained, and when being used with proper care having regard to the purpose for which the equipment is intended. Guardall supply a suitable power supply complying with this requirement.

Statutory Requirements

If you have any doubts concerning the suitability, connection, or use of this apparatus then consult a suitably qualified person before continuing.

Ringer Equivalence Number (REN)

REN is a customer guide to indicate the maximum number of apparatus that may be connected simultaneously to a single telephone line without affecting the bell (or tone) ringing characteristics of the items connected.

To calculate the maximum number of items that may be connected to a single exclusive telephone line, add all the REN values of the connected equipment. Telephones that are not marked with a REN value are assumed to have a REN of 1.

If a REN of 4 is marked on the apparatus then no other apparatus may be connected simultaneously unless that apparatus has been marked with a REN of 0. The maximum REN value allowed on any combination of simultaneously connected apparatus is 4. Guardall can not guarantee successful operation in an installation of mixed equipment, due to spread of characteristics. The voltage drop introduced by SmartDial Speech PX, where an auxiliary port is provided into the loop connection between the main apparatus and the PSTN, at 40mA line current, will not exceed 200mV. SmartDial Speech PX must not be used with any equipment which when introduced by any relevant wiring, causes a voltage drop exceeding 2 volts.

Dialling Modes

BS 6789: section 3.1 defines three dialling modes (Modes 1, 2 and 3). Modes 2 and 3 cover auto dialling devices, which play recorded messages. Mode 1 provided by SmartDial Speech PX may be used for all non-emergency (non 999/112) calls. Mode 1 specifies that the device must drop the line (hang - up) within 1 minute if it receives the standard BT tones for number unobtainable, Busy, Equipment engaged or special information. Calls not covered by modes 1, 2 or 3 must not be made. Alarm calls, since they use Mode 1 MUST NOT BE used for emergency 999/112 calls.

Locally Initiated Test Calls

A test call is initiated to all programmed reporting telephone numbers in turn, in the format programmed for that telephone store. The results of test calls are entered into the event log. Test calls in Ademco format will include the current dialler output status for all channels.

Default Configuration

The contents of SmartDial Speech PX's configuration can be defaulted to a known state by defaulting the host Control Panel's NV memory (refer to the Control Panel manual for details).

Remote Up/Download

It is possible to remotely access the Control Panel, by using a secure procedure, and perform engineering functions that would normally have required a site visit. These remote functions include PIN change, set/unset, event log upload, configuration data upload/download, etc.

LED Status Indicators

SmartDial Speech PX has 5 status LEDs.

Function	50v OK (Green)	Hook (Red)	Status (Orange)	Record (Green)	Play (Red)
Exchange Line Voltage OK	On				
Insufficient Exchange Line Voltage	Off				
On Line (Off Hook)		On			
Off Line (On Hook)		Off			
Line Activity		On	Flash		
Idle Status (every 6 seconds)		Off	Flash		
Ringing Detected	Flash		Flash		
SmartDial Speech PX Reset				Alternate flash	Alternate flash
Data Transmit	On		Flash		
Message Record				On	
Message Playback					On

Compatibility with BT 'Redcare' Lines

SmartDial Speech PX can be successfully used on BT Redcare lines due to the filtering out of the STU 'low tone' at the receive filter stage.

Timed Break Register Recall ("Star Services" in UK)

The 'Timed Break Recall' service available on digital exchanges in many countries is employed at the dial time if no dial tone is detected. This action requests a clear fresh line from the exchange and overcomes the malicious, or otherwise, blocking of the telephone line.

Available Facilities

SmartDial Speech PX Digital Alarm Communicators, manufactured by GUARDALL LTD, have been approved for use with the following facilities...

1. Alarm transmission and transmission/reception of configuration data.
2. Automatic Call Initiation.
3. Series connection if a specific auxiliary socket has been provided.
4. Detection of initial indication to proceed (dial tone).
5. Automatic dialling using DTMF tones.
6. Automatic Call Answering.
7. Stored number dialling.
8. Timed Break Register Recall.

Any other usage will invalidate the approval status, if as a result, the operation of SmartDial Speech PX ceases to conform to the standards against which they were tested and approved.

Repeat Attempts

The default Alarm Control Panel settings enable SmartDial Speech PX to make repeat attempts according to the following pattern:

1. CALL ATTEMPT PATTERN TO STORED PRIMARY NUMBER
2. first call attempt
3. <5 second delay>
4. first repeat attempt
5. <60 second delay>
6. second repeat attempt

7. CALL ATTEMPT PATTERN TO STORED BACKUP NUMBER
(If a backup number is programmed; otherwise END OF SEQUENCE)
8. <5 second delay>
9. first call attempt
10. <5 second delay>
11. first repeat attempt
12. <60 second delay>
13. second repeat attempt

14. END OF ATTEMPT SEQUENCE

It is essential that the programmed PRIMARY and BACKUP number stores do not contain the same number, or subsets of each number, such that primary and backup call attempts are made to the same number. Programming commands have been provided for this purpose.

Application Form for Installation of Modular Telephone Sockets

To the Customer:

If your current telephone socket is not equipped with the new modular telephone socket, you must have one fitted by your telephone service provider. Please complete this form and return it to your local telephone sales office. You will find the address and telephone number in your local telephone directory.

Name: _____

Address: _____

Postcode: _____

Telephone Number: _____

To Telephone Sales:

Please quote for the supply and fitting of a modular telephone socket at the above address. The equipment to be connected is a GUARDALL LTD SmartDial Speech PX Digital Alarm Communicator

The REN of the equipment is 1

Guardall Limited
Lochend Industrial Estate
Newbridge
Edinburgh EH28 8PL

Tel: 0131-333-2900
FAX: 0131-333-4919
www.guardall.co.uk

Technical Hotline: 0131-333-3802

Part Number: 320 710